

Respiratory Humidifier

Instructions for use

File No:MK/YF20-16

Ver:V1.5

Product name: Respiratory Humidifier

Model: RH-800P, RH-800

Manufacturer: Micomme Medical Technology Development Co., Ltd.

Manufacture address: No.6 Kesheng Road, Hi-Tech Zone,410221 Changsha, Hunan, PEOPLE'S
REPUBLIC OF CHINA

Website: www.micommed.com

Service hotline: +86 4000-2000-33

Expected Service life/Shelf life: 5 years(if used in accordance with this Instructions for use)

Software version : V1

Revised on: July 5th, 2024

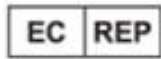

Name: Shanghai International Holding Corp. GmbH (Europe)

Add: Eiffestrasse 80, 20537 Hamburg, Germany

Tel: 0049-40-2513175

Fax: 0049-40-255726

TABLE OF CONTENTS

1. Product Overview	5
1.1 Intended Use	5
1.2 Target users	5
1.3 Intended target groups:	5
1.4 Indications and Contraindications	5
1.5 Clinical Benefits	6
1.6 WARNINGS AND CAUTIONS	6
1.7 Product Type / Model	7
1.8 Cybersecurity Description.....	7
2. Appearance and Accessories	8
2.1 Package List	8
2.2 Symbol Definitions	10
3. Prior to Use	12
3.1 Safety Considerations:	12
3.1.1 Safety hazard symbol notice:	12
3.1.2 Equipment misuse notice:	12
3.2 Set-up	12
3.3 Set-up Instructions	12
3.4 Setup Indicators	15
4. Operation	15
4.1 Display	15
4.2 Start / Stop therapy	16
4.2.1 Start therapy	16
4.2.2 Stop therapy	16
4.3 Turning off the power.....	16
4.4 Setup	16
4.4.1 Setup menu: Airway / Patient interface temperature	16
4.4.2 Setup menu: Bluetooth connection (For RH-800P only)	17
4.5 Memory function	17
4.6 Query the software version	17
5. Alarms	18
5.1 Type of Alarms	18
5.2 List of Alarms (RH-800P)	18
5.3 List of Alarms (RH-800)	20
5.4 Prompt message	20
5.5 Security characteristics.....	20
6 Clean and maintenance	20
6.1 Clean	20
6.2 Maintenance	21
7 Reordering	22

8 Disposal	22
9 Technical Specifications	22
9.1 Parameters	22
9.1.1 Performance	22
9.1.2 Recommended Environmental Conditions	23
9.1.3 Physical and Electronic Specifications	23
9.1.4 IEC 60601-1 Classifications.....	24
10 Guidance and manufacturer’s declaration - electromagnetic emissions and immunity	24

1. Product Overview

1.1 Intended Use

The Respiratory Humidifier is used to warm and humidify gases delivered to patients requiring mechanical ventilation or other positive-pressure breathing assistance.

ATTENTION: This device is for use under the supervision of trained healthcare professional in medical institutions.

1.2 Intended users:

Adequately trained healthcare professionals

1.3 Intended target groups:

Adult and children with type 1/ type 2 acute respiratory failure

1.4 Indications and Contraindications

Indications: type 1/ type 2 acute respiratory failure

Contraindications: There are no contraindications to the use of Respiratory Humidifier, but Respiratory Humidifier need to use with ventilators, so contraindications under invasive and noninvasive conditions of the ventilator were considered:

Absolute Contraindications for NIV:

<ul style="list-style-type: none"> ● Altered mental status; ● Respiratory arrest ; ● Unable to fit mask; ● Cardiorespiratory arrest; ● Cardiac arrest; ● Extreme psychomotor agitation; ● Severe haemodynamic instability; ● Nonhypercapnic coma; 	<ul style="list-style-type: none"> ● Multiple organ failure; ● Severe agitation or encephalopathy; ● Copious secretions; ● Uncontrolled vomiting; ● Inability to protect airway; ● Severe upper gastrointestinal bleeding or hemoptysis; 	<ul style="list-style-type: none"> ● Immediate endotracheal intubation necessary (except for Preoxygenation NIV); ● Facial trauma; ● Unstable cardiac arrhythmia; ● Pneumothorax; ● Recent upper airway or esophageal surgery;
---	--	---

Relative contraindications for NIV:

<ul style="list-style-type: none"> ● Altered mental status; ● Medically unstable—hypotensive shock, uncontrolled cardiac ischaemia or arrhythmia, uncontrolled copious upper gastrointestinal bleeding; ● Agitated, uncooperative; ● Unable to protect airway; 	<ul style="list-style-type: none"> ● Swallowing impairment; ● Excessive secretions not managed by secretion clearance Techniques; ● Multiple (ie, two or more) organ failure; ● Recent upper airway or upper gastrointestinal surgery; 	<ul style="list-style-type: none"> ● Mildly decreased level of consciousness; ● Progressive severe respiratory failure; ● Uncooperative patient who can be calmed or comforted;
--	--	--

Absolute contraindications for IV: No

Relative contraindications for IV:

<ul style="list-style-type: none"> ● Partial transection of the trachea; ● Coagulopathy with nasal intubation; 	<ul style="list-style-type: none"> ● Anatomic factors; ● Uncontrolled bleeding disorders; ● High ventilatory demands 	<ul style="list-style-type: none"> ● High oxygenation needs (positive end-expiratory pressure > 15 cmH2O or fraction of inspired oxygen of
--	---	--

<ul style="list-style-type: none"> ● Altered neck anatomy due to severe neck burns, and scarring from a previous tracheostomy; 	(minute ventilation > 15 L/min);	0.7) ; <ul style="list-style-type: none"> ● Active cutaneous infection over the proposed tracheostomy Site;
---	----------------------------------	---

1.5 Clinical Benefits

The Respiratory Humidifier is used to warm and humidify gases delivered to patients requiring mechanical ventilation or other positive-pressure breathing assistance.

The warmed and humidified gas can reduce cooling and desiccation of the upper airways, and enhance comfort and tolerance. Furthermore, it can moisten secretions to facilitate mucociliary clearance and reduce bronchoconstriction. The Respiratory Humidifier has invasive mode, humidification can prevent hypothermia, disruption of the airway epithelium, bronchospasm, atelectasis, and airway obstruction during invasive mechanical ventilation. Respiratory Humidifier combined with ventilator can help to improve oxygenation and reduce respiratory rate to attenuate signs of respiratory failure, it can treat patients with type 1/ type 2 acute respiratory failure and increase PaO₂/FiO₂ by 22.5~60 mmHg and decrease respiratory rate 2~4 breaths·min.

1.6 WARNINGS AND CAUTIONS

WARNINGS

- The use of breathing circuits, humidification chambers, other accessories or parts which are not approved by Micomme may impair performance or compromise safety.
- Do not add any attachments or accessories to the respiratory humidifier that are not listed in the instruction for use of the respiratory humidifier or accessory or the respiratory humidifier might not function correctly affecting the quality of the therapy or injuring the patient.
- Use of damaged components or accessories may impair the performance of this device or compromise safety.
- This device is a high flow device and should only be connected to a pipeline installation designed using a diversity factor that allows for the indicated high flow at a specified number of terminal outlets, in order to avoid exceeding the pipeline design flow, thereby minimizing the risk that the respiratory humidifier interferes with the operation of adjacent equipment.
- When mounting a respiratory humidifier adjacent to a patient ensure that the Humidifier is always securely mounted and positioned lower than the patient.
- Do not use this device without gas flow. If gas flow is interrupted, turn the respiratory humidifier off.
- Gas mixes, such as helium-oxygen mixtures, that have different physical or thermal properties from an air or air-oxygen mixture may impair performance or compromise safety.
- This device is not suitable for delivery of flammable anesthetic mixes or nitrous oxide.
- Remove any sources of ignition, such as cigarettes, an open flame, or materials which burn or ignite easily at high oxygen concentrations.
- Covering breathing tubes with a blanket or heating them in an incubator or with an overhead heater can affect the quality of the therapy or injure the patient.
- Avoid touching the heating plate to prevent scalding, because the surface temperature may exceed 75 °C.
- Do not fill the humidification chamber with water in excess of 37 °C.

- To avoid the risk of electric shock, this device must only be connected to a mains power supply with protective earth.
- Ensure that Invasive Mode is set for patients who have bypassed airways.
- Ensure that both Temperature Probe sensors are correctly and securely fitted. Failure to do so may result in gas temperatures in excess of 42°C being delivered to the patient.
- Do not use the Humidifier at an altitude above 3000 m (700 hPa) or outside a temperature of 18 ~ 28 °C. Using the Humidifier above this altitude or outside of this temperature range can affect the quality of the therapy or injure the patient.
- Ensure that appropriate ventilator and/or patient monitor alarms are set, connections are secure and a leak test is completed before use.
- To prevent disconnection of the tubing or tubing system during use, only tubes in compliance with ISO 5367 should be used.
- No modification of equipment or replacement of individual components is allowed.
- Do not position the respiratory humidifier so that it is difficult to disconnect the mains plug.
- This device is not suitable for use in the presence of a flammable anesthetic mixture.
- The oxygen concentration of the output gas may be inaccurate if the breathing tube is blocked. Ensure that the breathing pipe is not blocked.
- There is a risk of fire associated with oxygen equipment and therapy. Do not use near sparks or open flames.
- Smoking during oxygen therapy is dangerous and is likely to result in serious injury from fire.

CAUTIONS

- Use EP sterile water for injection or equivalent for humidification. Adding other substances to the water can have adverse effects.

1.7 Product Type / Model

Table 1 Type / Model difference

Type/Model	Operating Mode	Applicable Flow Range
RH-800P	Invasive Mode	10-60L/min (Invasive Mode)
	Smart Non-invasive mode	10-120L/min (Smart Non-invasive mode/
	Non-invasive Mode	Non-invasive Mode)
RH-800	Non-invasive Mode	10-120L/min

1.8 Cybersecurity Description (For RH-800P only)

Data Interface

Support BLE5 and compatible with BLE4.0, BLE4.1, BLE4.2 part of the function.

Access Control

The Bluetooth host can only connect to the respiratory humidifier by Bluetooth after being verified with the respiratory humidifier's specific password. After the connection is successful, the respiratory humidifier and Bluetooth host can exchange data through a specific communication protocol.

2. Appearance and Accessories

2.1 Package List

This device includes the following components and accessories.

1.Host of Respiratory Humidifier The picture is for reference only

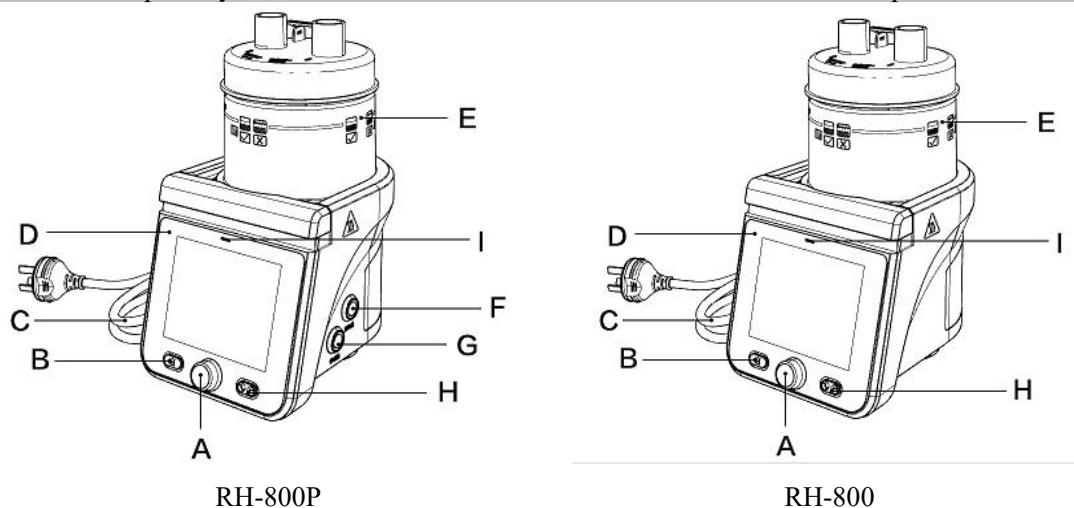

Figure 1

Item	Remark
A	<p>The respiratory humidifier will be able to set the temperature if this button is held down for 1s,and the humidifier will finish the the temperature setting if this button is held down for 1s again.</p> <p>The respiratory humidifier will start treatment if this button is held down for about 3s, The humidifier will stop treatment if this button is held down for about 3s again.</p>
B	<p>The mute button silences the respiratory humidifier's audible alarm. The muted time depends on the alarm condition. In general, alarms will be muted for 2 minutes.</p>
C	Connect the instrument to the network power supply
D	Display information
E	Device that allows gas to be heated and humidified by passing it over heated water.
F	The heater-wire cable insert to the device through the heater-wire connector.
G	The temperature probe cable insert to the device through the temperature probe connector.
H	For switching the modes such as invasive mode, smart non-invasive mode and non-invasive mode.
I	<p>The device is in the alarm state when the indicator light is red.</p> <p>The device is in treatment state when the light is yellow.</p>

2. Breathing Tube

The picture is for reference only

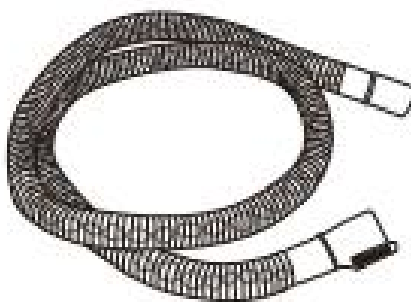

Figure 2

3. Heater-wire Cable(RHW-001)

The picture is for reference only

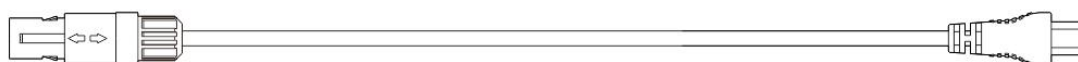

Figure 3

4. Temperature Probe Cable(RHW-002)

The picture is for reference only

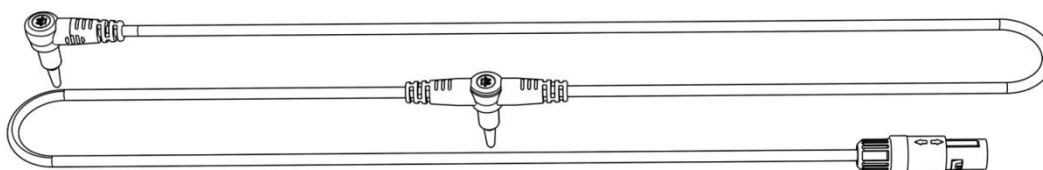

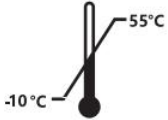

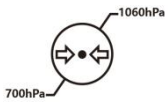















Figure 4

Item	Qty	Remark
Instruction for use	1	/
Quick Operation Guide	1	/
Certificate of conformity	1	/
Packing list	1	/
Humidification chamber(HC400)	1	Device that allows gas to be heated and humidified passing it over heated water.The accessory is consumable and optional.
Heater-wire Cable(RHW-001)	1	Wire inside the breathing circuit which heats the respiratory gases.Only for RH-800P and the accessory is consumable and optional
Temperature Probe Cable(RHW-002)	1	Sensor assembly for measuring temperature of respiratory gases traveling through the breathing circuit consists of a chamber and airway probe.Only for RH-800P and the accessory is consumable and optional.
Breathing Tube	1	Tubing that carries respiratory gases to and from the patient.The accessory is consumable and optional.

2.2 Symbol Definitions

Symbol	Definition	Symbol	Definition
	Non-invasive Mode		Invasive Mode
	Smart Non-invasive Mode		Alarm Low water level
	Alarm Breathing circuits connection failure		Alarm Temperature sensor
	Alarm High temperature		Alarm low temperature
	Alarm Heater-plate sensor		Max water level
	Attention Removal of humidification chamber		Exceed max water level
	Bluetooth on		Bell, cancel temporary (IEC 60417-5576-2)
	Caution (ISO 7000-0434A)		Type BF Applied Part (IEC 60417-5333)
	Consult instructions for use (ISO 7000-1641)		Not to be serviced by users (ISO 7010-P069)
	Warning, Hot surface (ISO 7010-W017)		Non-ionizing electromagnetic radiation (IEC 60417-5140)
	Non-sterile (ISO 7000-2609)		MR Unsafe (ASTM F2503-23)
	This way up (ISO 7000-0623)		Keep away from sunlight (ISO 7000-0624)

Symbol	Definition	Symbol	Definition
	Fragile, handle with care (ISO 7000-0621)		Keep dry (ISO 7000-0626)
	Temperature limit (ISO 7000-0632)		Humidity limitation (ISO 7000-2620)
	Atmospheric pressure limitation (ISO 7000-2621)		WEEE (IEC 60417-6414)
	Medical Device (ISO 15223-1)		Batch code (ISO 7000-2492)
	Manufacturer (ISO 7000-3082)		Authorized representative in the European Community
	Date of Manufacture (ISO 7000-2497)		Serial number (ISO 7000-2498)
	Catalogue number (ISO 7000-2493)		Use-by date (ISO 7000-2607)
	CE Marking		Distributor (ISO 7000-3724)
	Importer (ISO 7000-3725)		Stacking limit by number (ISO7000-2403)
	Unique device identifier (ISO15223.1-5.7.10)	/	/

3. Prior to Use

3.1 Safety Considerations:

3.1.1 Safety hazard symbol notice:



DO NOT USE IF PRODUCT SHOWS VISIBLE DAMAGE AND MATERIAL DEGRADATION.

3.1.2 Equipment misuse notice:

Do not use product if package is damaged or unintentionally opened before use.

All modifications, upgrades, or repairs must be performed by an authorized specialist.

3.1.3 Notice to users and/or patients:

Any serious incident that has occurred in relation to the device should be reported using the contact details provided in this Instruction for Use and to the competent authority of the Member State in which the user and/or patient is established.

3.2 Set-up

The Humidifier can either be placed on a flat stable surface or mounted to a ventilator, pole stand or medical equipment rail with an approved mounting bracket. The system shall be installed according to Electromagnetic Compatibility information contained instructions for use.

ATTENTION:

- Keep the device at least 5 cm away from the wall, and make sure that the air inlet of ventilator and other positive-pressure breathing system is not covered by curtains, quilt and other substances.
- In order to guarantee smooth operation of the device, Make sure that the air circulation around the device, and keep device from heating or cooling equipment (cooler, forced vent, air conditioner and so on).

3.3 Set-up Instructions

1. Visually inspect the Humidifier and accessories for damage before use and replace if damaged.
2. Slide the Humidification Chamber onto the Humidifier and connect Breathing Circuit (refer to the Humidification Chamber and Breathing Circuit User Instructions for further details).
3. For Invasive Mode and Smart Non-invasive mode: Insert the Temperature Probe Connector to the blue socket on the Humidifier. See Figure 5 and Figure 6 for detail.
4. For Invasive Mode and Smart Non-invasive mode: Push the Chamber Probe and Airway Probe into the Breathing Circuit making sure they are correctly located and pushed into place. The probe lead can be secured using Breathing Circuit Clips. See Figure 5 and Figure 6 for detail.
5. For Invasive Mode and Smart Non-invasive mode: Insert the Heater-wire Adapter Connector to the yellow socket on the Humidifier. See Figure 5 and Figure 6 for detail.
6. For Invasive Mode and Smart Non-invasive mode: Connect the other end of the Heater-wire Adapter to the Breathing Circuit socket. The humidification system is now set up. See Figure 5 and Figure 6 for detail.
7. Plug the Mains plug of the power cord into a Mains socket-outlet. The Humidifier will

default to smart non-invasive Mode. After turning on the Humidifier, look at the display and alarm indicators to visually confirm that they turn on then off. If a fault is detected, send for servicing.

The humidification system is now ready for use.

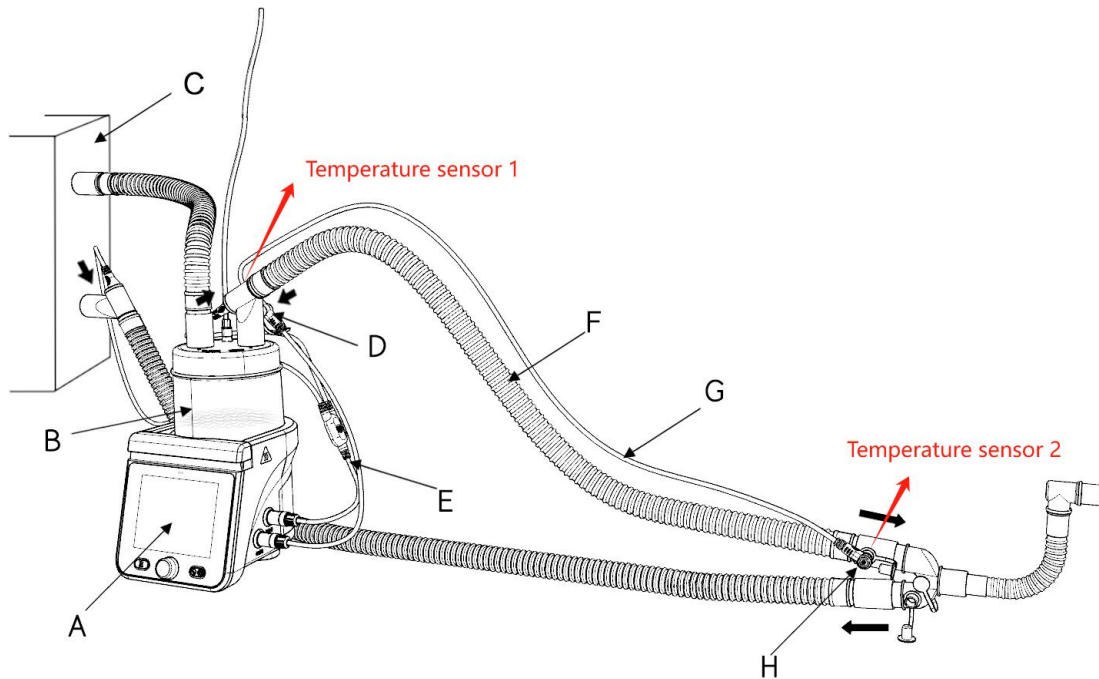

Figure 5 The connection of accessories in invasive mode(For RH-800P only)

	Item	Remark
A	Host of RH-800P	N/A
B	Humidification Chamber	N/A
C	other positive-pressure breathing assistance	N/A
D	Temperature Probe	For measuring temperature of gas out from the humidification chamber
E	Heater-wire Cable	N/A
F	Breathing tube	N/A
G	Temperature Probe Cable	N/A
H	Temperature Probe	For measuring temperature of gas pathway

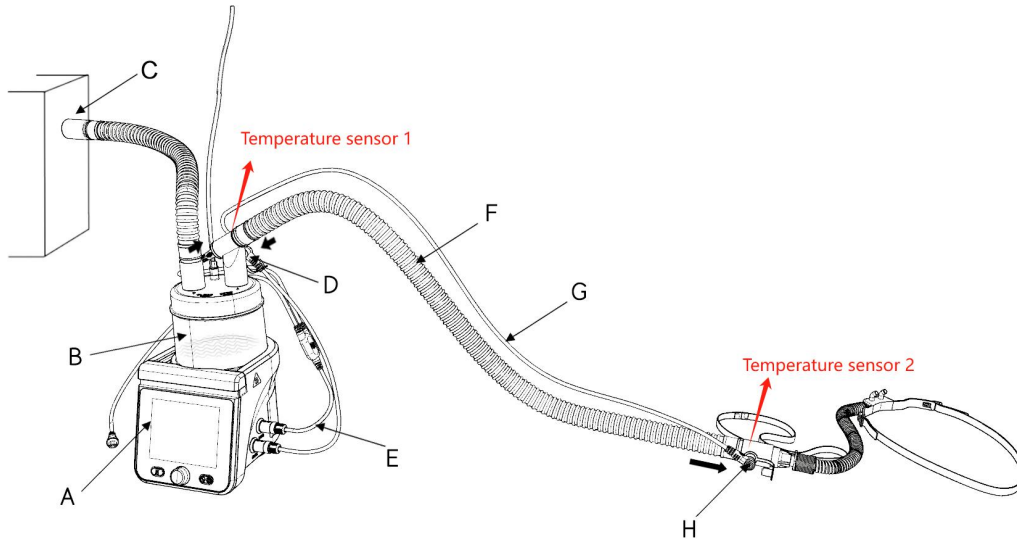
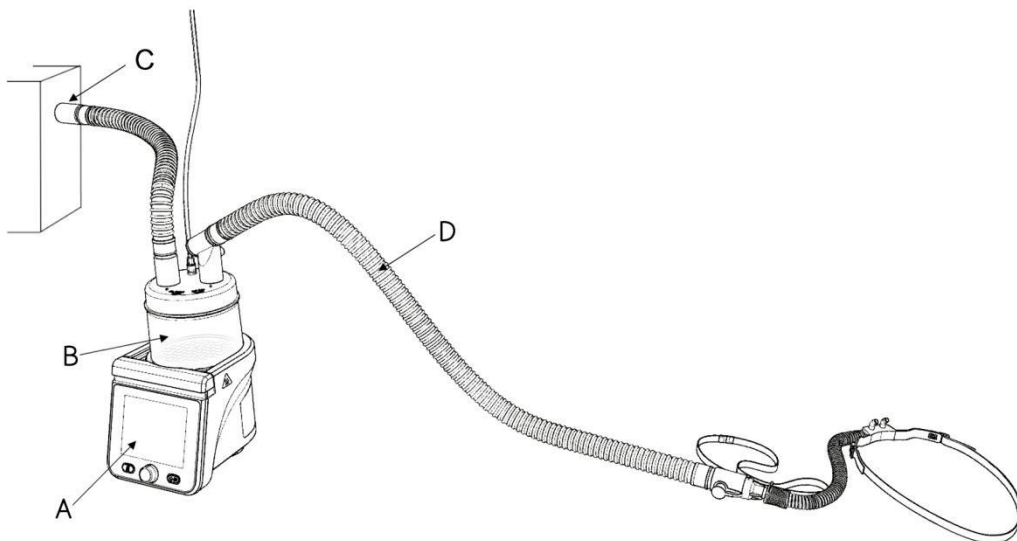

Figure 6 The connection of accessories in Smart Non-invasive mode(For RH-800P only)

	Item	Remark
A	Host of RH-800P	N/A
B	Humidification Chamber	N/A
C	other positive-pressure breathing assistance	N/A
D	Temperature Probe	For measuring temperature of gas out from the humidification chamber
E	Heater-wire Cable	N/A
F	Breathing tube	N/A
G	Temperature Probe Cable	N/A
H	Temperature Probe	For measuring temperature of gas pathway



**Figure 7 The connection of accessories in Non-invasive mode
(Without Temperature Probe Cable and Heater-wire Cable)**

	Item	Remark
A	Host of RH-800P	N/A
B	Humidification Chamber	N/A
C	other positive-pressure breathing assistance	N/A
D	Breathing tube	N/A

3.4 Setup Indicators

The RH-800P/RH-800 setup indicators, placed on the front panel, are intended to aid the user in identifying problems with the incorrect setup of the device and its accessories.

3.4.1 Heater-wire Cable Connection (Only for RH-800P)

The logo  on the LCD flashes if the heater-wire cable is damaged and it is connected incorrectly. The heating plate stops heating if this alarm is active.

3.4.2 Temperature Probe Connection (Only for RH-800P)

The logo  on the LCD flashes if the temperature probe cable is damaged and not plugged into the device.

3.4.3 Humidification Chamber Connection (For RH-800P/RH-800)

The logo  on the LCD flashes if the humidification chamber is not installed on the device.

4. Operation

4.1 Display

The LCD screen displays the therapy mode, temperature of therapy and alarm status.

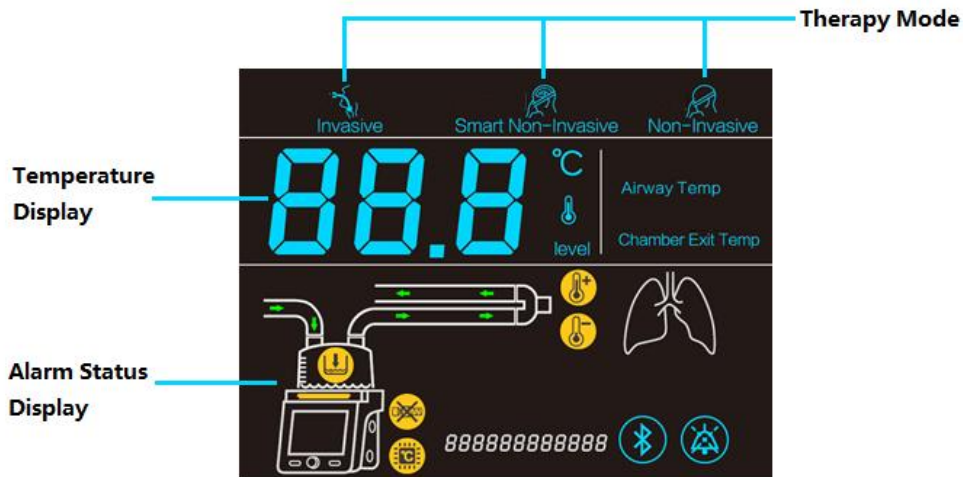

ATTENTION:

- The Airway Temp is identical to the temperature of Breathing tube's Temperature sensor 2 (Location is shown in Figure 5).
- The Chamber Exit Temp is identical to the temperature of Breathing tube's Temperature sensor 1 (Location is shown in Figure 5).
- Values on this LCD screen and other screens throughout the instructions for use are examples only.

4.2 Start / Stop therapy

ATTENTION:

- The responsible organization should ensure the compatibility of the respiratory humidifier and all parts and accessories intended to be used to connect to the patient prior to use.

4.2.1 Start therapy

1. Fit your patient interface (mask, catheter mount or nasal oxygen cannula) as described in the instructions for use.
2. Lie down and arrange the air breathing tube so that it is free to move if you turn in your sleep or arrange the tubing so it is comfortable in your wheelchair.
3. To start treatment, just press Push dial and hold about 3s and the status indicator lamp on the LCD screen appears green.

4.2.2 Stop therapy

You can stop therapy at any time, simply remove the patient interface and press Push dial and hold about 3s to stop airflow.

ATTENTION:

- When using with oxygen, turn off oxygen flow before stopping therapy.

4.3 Turning off the power

1. Stop the therapy.
2. Disconnect the device from the Mains power, just pull out the power cord from the Mains socket-outlet.

Note:After turning off the power supply, please wait for at least 1.5 hours and do not remove the humidifier water box from the humidifier immediately to avoid burns.

4.4 Setup

Setup menu: Mode Selection (For RH-800P only)

- 1.Plug the Mains plug into the Mains socket-outlet;
- 2.Press the Mode selection button to select proper therapy mode.

ATTENTION:

- The default therapy mode of RH-800P is Smart Non-invasive.

4.4.1 Setup menu: Airway / Patient interface temperature

ATTENTION:

- The temperature of Chamber exit can't be tuned by users.
- In the therapy mode, the temperature display on LCD screen is default the Patient interface temperature, you can press and hold the Mute button for 3 seconds, and will display the temperature of Chamber exit.
- The device takes less than 30 minutes to preheat from the starting temperature of (23 ± 2) °C to the set temperature.The logo “” flashes when device is in the warm-up time.
- The temperature can be set in standby and therapy state.
 1. Just click the Control Dial, and digits of Airway temperature flashes on the screen.
 2. Rotate the control dial to set the Airway temperature you want,and the temperature value decreases in the counterclockwise direction and increases in the clockwise direction. The

Settings in each mode are as follows:

Invasive Mode: 35°C~40°C (The default value:39°C)

Smart Non-invasive: 31°C~37°C (The default value:34°C)

Non-invasive: 1 level-7 level (The default value:4 level)

3. Click the Control Dial, and digits of Airway temperature stop flashing, and the temperature setup finished.

4.4.2 Setup menu: Bluetooth connection (For RH-800P only)

The respiratory humidifier(RH-800P) connects to the matching ventilator via Bluetooth, and uses a specific protocol to exchange data such as temperature and flow rate with the ventilator, in addition, the treatment temperature and treatment status can be synchronized with the ventilator.

ATTENTION:

- The RH-800P can only connect with Micomme approved devices.
- The device has Bluetooth transmission function in the Smart Non-invasive mode and the Bluetooth is default on.
- Press the alarm mute button key and mode button at the same time about 3s to disconnect the Bluetooth connection between the RH-800P and the matching ventilator.
- If it any other suspected cybersecurity event occurs,please refer to the respiratory Humidifier(RH-800P) or matching ventilator manual to disconnect the Bluetooth connection,but the respiratory humidifier(RH-800P) can be used still,and call Customer Care at +86 4000-2000-33.

Operation procedure:

1. Plug the Mains plug into the Mains socket-outlet, confirm the bluetooth is on and the symbol



flashes on the LCD screen.

2. Use Micomme approved devices with Bluetooth function to search for it, and make sure the Bluetooth address is the same with the address displayed on the LCD screen of Respiratory Humidifier.For example, the Bluetooth address displayed on the respiratory humidifier



represents the address is d0:bb: 59: 88: 0b: bb.

3. Choose the correct Bluetooth address and connect the Respiratory Humidifier, when

connected successfully, the  on the LCD screen stop flashing and will constantly on.

4.5 Memory function

If a power failure occurs during the treatment of RH-800P device, the device will record the last operating mode, temperature, and treatment status set before the power failure after the device restarts.

If a power failure occurs during the treatment of RH-800 device, the device will record the temperature level, and treatment status set before the power failure after the device restarts.

4.6 Query the software version

Note: The software version number cannot be queried when the device is in the therapy state.

1. You can query the software by pressing the mute button for 3 seconds when the device is in invasive mode and non-invasive mode and in the standby state.
2. In the Smart Non-invasive mode, you can query the software by pressing the mute button for 3 seconds when the device is in the standby state and the Bluetooth is turned off.

5. Alarms

5.1 Type of Alarms

When the device is abnormal, the system will automatically make an abnormal alarm and inform the user to make corresponding adjustments. Users can refer to “5.2 List of Alarms(RH-800P)” and “5.3 List of Alarms(RH-800)” to exclude alarms, so as to prevent adverse effects on patients and equipment due to abnormal conditions, and ensure normal treatment of patients and safe use of equipment. The alarm function should be validated before using the device. The user can verify whether the alarm is normal by unplugging the heater-wire probe.



This device only have High Priority Alarms. The High Priority Alarm has the following tips:





- (1) Voice prompt: A sound cue is " * * * * " (representing three beeps, A pause, and two more beeps), with A range of sound pressure greater than 50dB (A).
- (2) Picture prompt: A prompt for an image flashes in the graphical area of the display screen.
- (3) Status indicator prompt: The status indicator lamp appears red and flashes at 2Hz in abnormal response.

If multiple alarm conditions occur simultaneously, the device will correspond to several alarm conditions at the same time.

You can mute an alarm by pressing the alarm mute button. By pressing the Mute button again, the alarm sounds again except during muting periods. For a high priority alarm, if after about two minutes the problem is still present, the alarm will sound again.

5.2 List of Alarms (RH-800P)

Priority	Picture prompt	Message	Cause & Possible Action	Delay
High		Check the Heater-wire Cable if it is damaged and it is connected correctly.	<i>The device cannot detect the Heater-wire Cable.</i> Possible Action: 1. Check the Heater-wire Cable if it is damaged. 2. Check the Heater-wire Cable and if it is plugged into device and if it is plugged to the breathing tube correctly. 3. Re-connect the Heater-wire Cable or restart the device. 4. If still persists, contact Micomme for solutions.	About 2s
High		Check the Temperature Probe Cable if it is damaged and it is plugged into device	<i>The device cannot detect the Temperature Probe Cable.</i> Possible Action: 1. Check the Temperature Probe if it is damaged and it is plugged into device.	About 12s

Priority	Picture prompt	Message	Cause & Possible Action	Delay
			<p>2.Re-connect the temperature probe cable or restart the device.</p> <p>3.If still persists, contact Micomme for solutions.</p>	
High		<p>Heater plate failure. Check the heater plate</p>	<p>The heater plate temperature sensor is detected to be short-circuited or open-circuited.</p> <p>Possible Action:</p> <ol style="list-style-type: none"> 1.Stop treatment and restart the device. 2.If still persists, contact Micomme for solutions. 	≤14s
			<p>The heater plate disconnected from the power supply.</p> <p>Possible Action:</p> <ol style="list-style-type: none"> 1.Stop treatment and restart the device. 2.If still persists, contact Micomme for solutions. 	about 5min
High		High Temperature	<p>The airway temperature in the Invasive mode is higher than 42 °C, or the airway temperature in the Smart Non-invasive mode is higher than 39°C.</p> <p>Possible Action:</p> <ol style="list-style-type: none"> 1. Disconnect the power wire and wait for the temperature falls down; 2. Change the Temperature Probe Cable; 3. If still persists, contact Micomme for solutions. 	About 32s
High		Low Temperature	<p>In invasive therapy mode, the airway temperature lower than 34°C. In Smart Non-invasive mode, the airway temperature lower than 30°C.</p> <p>Possible Action:</p> <ol style="list-style-type: none"> 1.Check if the temperature probe is loose, plug tightly if required. 2.Press the Mute button and prolong the duration of heating. Confirm if the temperature is lower than required, take measures to keep the breathing tube warm. 3. Change the Temperature Probe Cable. 4. If still persists, contact Micomme for solutions. 	About 3min
High		Low water level	<p>Detected that the water in the humidification chamber is empty.</p> <p>Possible Action:</p> <p>Stop therapy and feed water into the humidification chamber.</p>	About 20min

5.3 List of Alarms (RH-800)

Priority	Picture prompt	Message	Cause & Possible Action	Delay
High		Heater plate failure. Check the heater plate!	<i>The heater plate temperature sensor is detected to be short-circuited or open-circuited.</i> Possible Action: 1.Stop treatment and restart the device. 2.If still persists, contact Micomme for solutions.	≤ 14s
			<i>The heater plate disconnected from the power supply.</i> Possible Action: 1.Stop treatment and restart the device. 2.If still persists, contact Micomme for solutions.	about 5min

5.4 Prompt message

Display (Flashing Symbol)	Prompt information	Cause	Action
	Removal of Humidification Chamber	Detect the removal of humidification chamber.	Install the humidification chamber

5.5 Security characteristics

When the temperature of the humidifier heating plate reaches (120±5) °C, the heating plate will automatically power off and emit a sound cue is " * * * * " (representing three beeps, A pause, and two more beeps).

6 Clean and maintenance

6.1 Clean

The cleaning described in this section should be carried out between uses.

Components that require surface cleaning:

- Host of respiratory humidifier
- Heater-wire Cable
- Temperature Probe Cable

Note:The disposal method of breathing tube and humidification chamber after use is described in their instructions.

Prerequisites:

- The manufacturer's instructions are observed.
- An uncontaminated, lint-free cloth soaked in surface disinfectant is used for the cleaning surface disinfection.

Warning:

Risk due to penetrating liquid. Penetrating liquid may cause the following:

- Damage to the device
- Electric shock
- Device malfunctions

Do not immerse the humidifier or accessory electrical connectors in any liquid.

Cleaning procedure:

1. Disconnect the device from the Mains socket-outlet.
2. Transport the device and its accessories to the disposal room. Remove all accessories from the device and drain the remaining water from humidification chamber.
3. Wipe off obvious soiling with a disposable cloth soaked in 75% alcohol by volume. Dispose of the cloth.
4. Wipe all surfaces with a new cloth. After that, there must no longer be any soiling visible.
5. Wipe cleaned surfaces again to visibly wet all surfaces to be cleaned with 75% alcohol by volume.
6. At the end of the contact time, moisten a new, uncontaminated and lint-free cloth with water (at least drinking water quality).
7. Wipe all surfaces until no remains of the surface disinfectant, such as foam residues or streaks are visible.
8. Wait until the surfaces are dry.
9. Check the surfaces for visible damage and, if necessary, replace the product.
10. Transport the device and its accessories to the dedicated equipment storage room for storage.

6.2 Maintenance

In order to keep the device in good working condition, it is necessary to perform maintenance at regular intervals.

6.2.1 Respiratory humidifier Maintenance***Annually***

Check device for physical damage:

- Check the power supply cords for damage, contact Micomme for replacing if damaged.
- Check the heater plate for deep scratching etc., contact Micomme for replacing if damaged.
- Check the heater wire adaptor for kinks, abrasions, and damaged connectors. Check that the plugs couple with the sockets on the device.

6.2.2 Temperature probe Maintenance***Every Six months***

Visually check the temperature probes for physical damage:

- Check that the probe's glass thermistor has not been damaged. If damaged contact Micomme for replacing.

- Inspect the probe’s glass thermistor for deposit of foreign materials. Clean probes as required.
- Check the probe cable for kinks and abrasions etc.
- Check that the probe connectors couple with device sockets.

7 Reordering

Humidification chamber(HC400), Heater-wire Cable(RHW-001) , Temperature Probe Cable(RHW-002) and Breathing Tube are consumable accessories. If you need to purchase, please contact the manufacturer.

8 Disposal

This procedure covers the correct disposal of electronic medical devices that are disposed by the hospital in accordance with the WEEE regulations as well as the hospital's own procedures.

Warning:WEEE must only be disposed of via hospital approved contractors and on no account can be taken home or resold for personal profit due to:

- The requirements of the WEEE directive
- The risk of incorrect disposal of hospital marked items
- The data protection issues associated with stored data

References:2012/19/EU Waste Electrical and Electronic Equipment (WEEE) Directive

Procedure

Once the hospital has determined the medical device is no longer serviceable and/or desires to dispose of the equipment, the device should be given to the hospital's designated e-waste recycling company for processing.

1. If the hospital has not already contracted with an e-waste recycling company, then the following link may be used to identify potential recycling companies.

EU:

<https://www.environmental-expert.com/companies/keyword-electronic-waste-recycling-12718/location-europe>

Worldwide:

<https://www.environmental-expert.com/services?keyword=e-waste+recycling>

2. Until the item(s) to be recycled are collected by a recycling company, the item(s) should be placed in a secure, well-ventilated area that has no access to drains. It must be kept separate from all other waste/reuse items.

Warning: The Humidification Chamber(HC400) should be cleaned and disinfected according to its instructions and then disposed according to the above procedure.

9. Technical Specifications

9.1 Parameters

9.1.1 Performance

	Invasive Mode	Non-invasive Mode / Smart Non-invasive Mode
Airway Control Temperature Range	35 °C~ 40 °C	31 °C~ 37 °C
Gas Temperature	±2 °C	

Measurement Accuracy		
Gas Temperature Measurement Uncertainty	U=0.4°C K=2	
Applicable Flow Range	10L/min-60 L/min	10L/min-120 L/min
Humidity Performance	>33 mg/L	>12 mg/L

9.1.2 Recommended Environmental Conditions

	Normal working condition	Transport / Storage condition
Ambient temperature	18 °C ~ 28 °C	-10 °C ~ 55 °C
Relative humidity	15% ~ 70%	15% ~ 93% (Non-condensing)
Atmospheric pressure	700 ~ 1060 hPa	N/A
Operating altitude	Below 3000m	N/A

9.1.3 Physical and Electronic Specifications

Dimensions	18.0 cm(L) × 13.8 cm(W) × 14.0 cm(H)			
Weight	About 1.5 kg			
Humidification chamber capacity	400 mL Note:(1)The chamber will be boiled dry after 4h to 6h with full of water when the flow rate is set to 40L/min and the temperature is set to 37°C. (for Invasive Mode and Smart Non-invasive mode) (2) The chamber will be boiled dry after 9h to 11h with full of water when the flow rate is set to 40L/min and the temperature gear is set to 4. (for Non-invasive Mode)			
Mains Supply	220V-240V ~50/60Hz,300VA			
Rated Power	1.5 A			
Heater-plate Output	180 W			
Heater-wire Output	66 W			
Heating Plate Thermal Cutout	(120±5)°C			
Maximum limited pressure	6 kPa			
Compliance Note:Breathing tube is a certified product compliant with ISO5367	Patient Category	Intended delivered volume (mL)	Compliance Limit ml/hPa (ml/cmH ₂ O)	At Pressure hPa (cmH ₂ O)
	Adult	≥300	5	60 ± 3
Flow resistance Note:Breathing tube is a certified product compliant with ISO5367	Patient Category	Intended delivered volume (mL)	Flow resistance limit hpa/l/min [cmH ₂ O/l/min]	At flow l/min
	Adult	≥300	0.06	30
Leakage	Breathing tube is a certified product compliant with ISO5367			

	The Humidification Chamber doesn't leak at the Maximum limited pressure.
--	--

9.1.4 IEC 60601-1 Classifications

Protection against electric shock	Class I
Applied part	Type BF
Type of Protection Against Ingress of Water	IPX1
Mode of operation	Continuous operation

10 Guidance and manufacturer's declaration - electromagnetic emissions and immunity

The device complies with the electromagnetic compatibility requirements of IEC 60601-1-2. Users shall install and use according to the electromagnetic compatibility information contained in the instruction for use.

Before using the device, please evaluate the surrounding electromagnetic compatibility environment, so as to maintain BASIC SAFETY and ESSENTIAL PERFORMANCE.

The device needs special precautions regarding EMC and needs to be installed and put into service according to EMC information provided in this document.

The emissions characteristics of this equipment make it suitable for use in industrial areas and hospitals (CISPR 11 class A). If it is used in a residential environment (for which CISPR 11 class B is normally required) this equipment might not offer adequate protection to radio-frequency communication services. The user might need to take mitigation measures, such as relocating or re-orienting the equipment.

The performance of the RH-800, RH-800P that determined to be "The display works normally, device runs without trouble, and the output of specific enthalpy is normal" . Operator can expect the performance is not normal if the ESSENTIAL PERFORMANCE is lost or degraded due to EM DISTURBANCES.

WARNINGS

- Don't near active HF surgical equipment and the RF shielded room of an ME system for magnetic resonance imaging, where the intensity of EM disturbances is high.
- Use of this equipment adjacent to or stacked with other equipment should be avoided because it could result in improper operation. If such use is necessary, this equipment and the other equipment should be observed to verify that they are operating normally.
- Use of accessories, transducers and cables other than those specified or provided by the manufacturer of this equipment could result in increased electromagnetic emissions or decreased electromagnetic immunity of this equipment and result in improper operation."
- Portable RF communications equipment (including peripherals such as antenna cables and external antennas) should be used no closer than 30 cm (12 inches) to any part of the equipment, including cables specified by the manufacturer. Otherwise, degradation of the performance of this equipment could result.

Accessories related to EMC

Temperature Probe Cable	Length1:2045mm Length 2:370mm
-------------------------	-------------------------------

Heater-wire Cable	355mm
-------------------	-------

Electromagnetic compatibility information

Table 1 Guidance and manufacturer's declaration - electromagnetic emissions

Emissions test	Compliance
RF emissions CISPR 11	Group 1
RF emissions CISPR 11	Class B
Harmonic emissions IEC 61000-3-2	Class A
Voltage fluctuations/Flicker emissions IEC 61000-3-3	Applicable

Table 2 Guidance and manufacturer's declaration - electromagnetic Immunity

Immunity Test	IEC 60601-1-2 Test level	Compliance level
Electrostatic discharge (ESD) IEC 61000-4-2	±8 kV contact ±2 kV, ±4 kV, ±8 kV, ±15 kV air	±8 kV contact ±2 kV, ±4 kV, ±8 kV, ±15 kV air
Electrical fast transient/burst IEC 61000-4-4	±2 kV for power supply lines ±1 kV signal input/output 100 kHz repetition frequency	±2 kV for power supply lines Not Applicable 100 kHz repetition frequency
Surge IEC 61000-4-5	±0.5 kV, ±1 kV differential mode ±0.5 kV, ±1 kV, ±2 kV common mode	±0.5 kV, ±1 kV differential mode Not Applicable
Voltage dips, short interruptions and voltage variations on power supply input lines IEC 61000-4-11	0 % UT; 0,5 cycle. At 0°, 45°, 90°, 135°, 180°, 225°, 270° and 315°. 0 % UT; 1 cycle and 70 % UT; 25/30 cycles; Single phase: at 0°. 0 % UT; 250/300 cycle	0 % UT; 0,5 cycle. At 0°, 45°, 90°, 135°, 180°, 225°, 270° and 315°. 0 % UT; 1 cycle and 70 % UT; 25/30 cycles; Single phase: at 0°. 0 % UT; 250/300 cycle
Power frequency magnetic field IEC 61000-4-8	30 A/m 50 Hz/60 Hz	30 A/m 50 Hz/60 Hz
Conducted RF IEC61000-4-6	3 V 0,15 MHz – 80 MHz 6 V in ISM and amateur radio bands between 0,15 MHz and 80 MHz 80 % AM at 1 kHz	3 V 0,15 MHz – 80 MHz 6 V in ISM and amateur radio bands between 0,15 MHz and 80 MHz 80 % AM at 1 kHz
Radiated RF IEC61000-4-3	10 V/m 80 MHz – 2,7 GHz 80 % AM at 1 kHz	10 V/m 80 MHz – 2,7 GHz 80 % AM at 1 kHz

NOTE U_T is the a.c. mains voltage prior to application of the test level.

Table 3 Test specifications for ENCLOSURE PORT IMMUNITY to RF wireless communications equipment

Test Frequency (MHz)	Band (MHz)	Service	Modulation	IMMUNITY TEST LEVEL (V/m)
385	380 to 390	TETRA 400	Pulse modulation 18 Hz	27
450	430 to 470	GMRS 460, FRS 460	FM ± 5 kHz deviation 1 kHz sine	28
710	704 to 787	LTE Band 13, 17	Pulse modulation 217 Hz	9
745				
780				
810	800 to 960	GSM 800/900, TETRA 800, iDEN 820, CDMA 850, LTE Band 5	Pulse modulation 18 Hz	28
870				
930				
1 720	1 700 to 1 990	GSM 1800; CDMA 1900; GSM 1900; DECT; LTE Band 1, 3, 4, 25; UMTS	Pulse modulation 217 Hz	28
1 845				
1 970				
2 450	2 400 to 2 570	Bluetooth, WLAN, 802.11 b/g/n, RFID 2450, LTE Band 7	Pulse modulation 217 Hz	28
5 240	5 100 to 5 800	WLAN 802.11 a/n	Pulse modulation 217 Hz	9
5 500				
5 785				

Table 4 Guidance and manufacturer's declaration - electromagnetic Immunity

Radiated RF IEC61000-4-39 (Test specifications for ENCLOSURE PORT IMMUNITY to proximity magnetic fields)	Test Frequency	Modulation	IEC 60601-1-2 Test Level (A/m)	Compliance level (A/m)
	30 kHz	CW	8	8
	134,2 kHz	Pulse modulation 2.1 kHz	65	65
	13,56 MHz	Pulse modulation 50 kHz	7,5	7,5